

PICAXE DEVELOPMENT BOARD (AXE091)

Description:

The PICAXE development board allows circuits for any size/revision of PICAXE chip (8 / 14 / 18 / 20 / 28 / 40) to be quickly tested using a prototyping breadboard. The development board provides power and computer download connections, as well as simple input and output devices for testing purposes.

This datasheet provides circuit information for the PICAXE Development board only. Please see the main PICAXE manuals for information on how to use the software and how to build circuits.

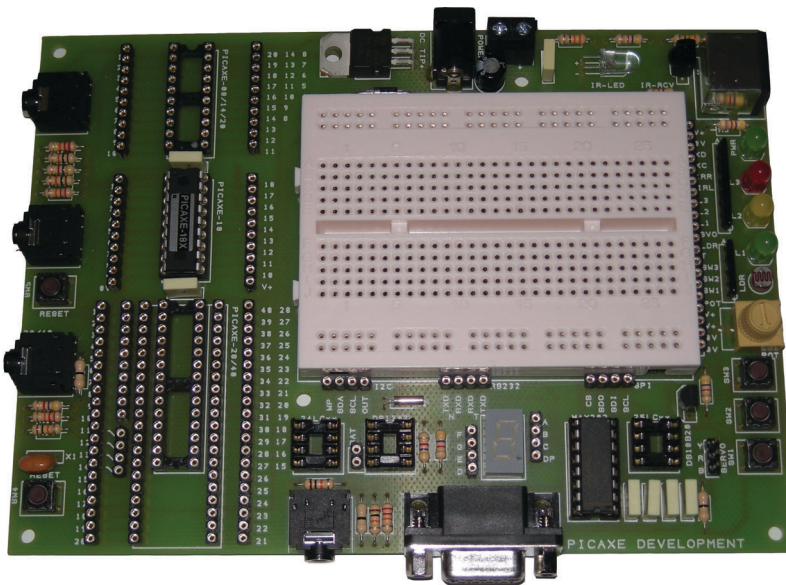

Features:

- Supports all 8/14/18/20/28/40 pin PICAXE chips.
- Computer download circuit pre-configured on PCB.
- Large breadboard area.
- Regulated power supply or battery powered, with LED power indicator.
- 3 LED indicator outputs.
- 3 Digital switch inputs.
- LDR and preset resistor analogue inputs.
- DS18B20 digital temperature sensor
- Infra red sensor and LED output
- Keyboard connector
- Serial (inverted and true (MAX202 buffered)) RS232 connectors
- Sockets for I2C and SPI memory chips (not supplied)
- Socket and battery connector position for DS1307 Real Time Clock (not supplied)

Assembly:

The PICAXE development board is supplied fully assembled and tested and is supplied with a PICAXE-18M2 microcontroller. Other PICAXE chips may be purchased separately.

If desired the spacer set provided may be fitted to lift the bottom of the board off the work surface. Please use all 6 spacers to help prevent the board flexing whilst in use.

For full datasheet and instructions please see:
www.picaxe.com/docs/axe091.pdf

Optional Components (not included)

9V Power Supply (UK style plug)	PWR009A
DS1307 Real Time Clock IC	MIC055
3V CR2032 Lithium Cell	BAT004
Lithium Cell Holder	BAT004H-SM
25LCxx SPI EEPROM	-
Radio Control Servo	GBX010
PS2 style Computer Keyboard	-
9 way Serial Cable	CAB010

PICAXE Circuit Diagram (08 / 14/ 20 pin devices)

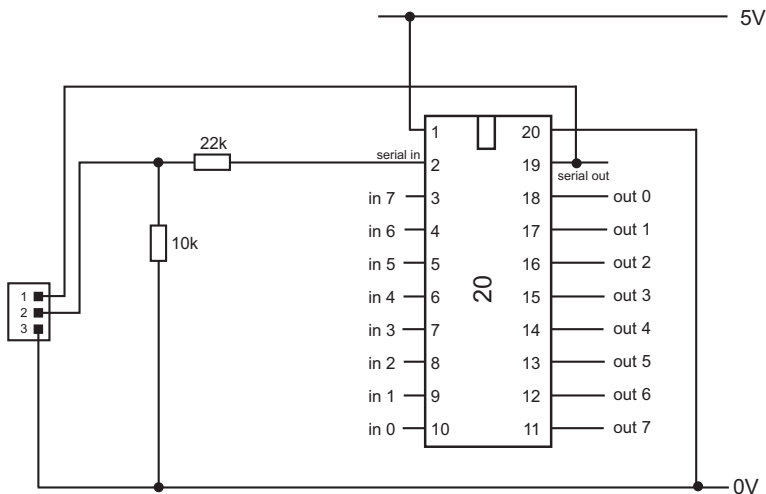
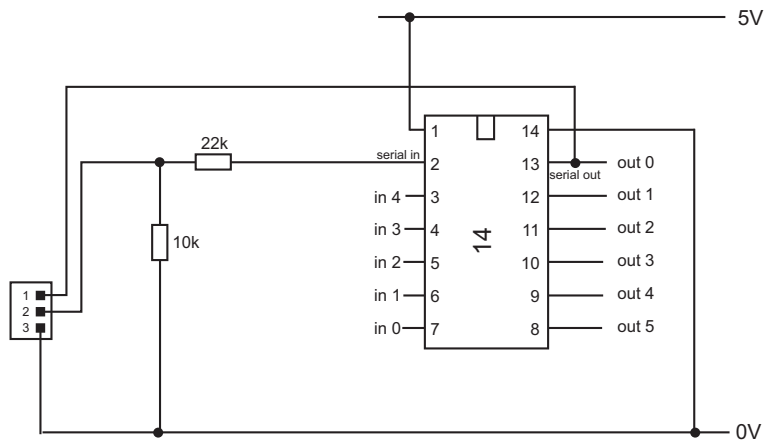
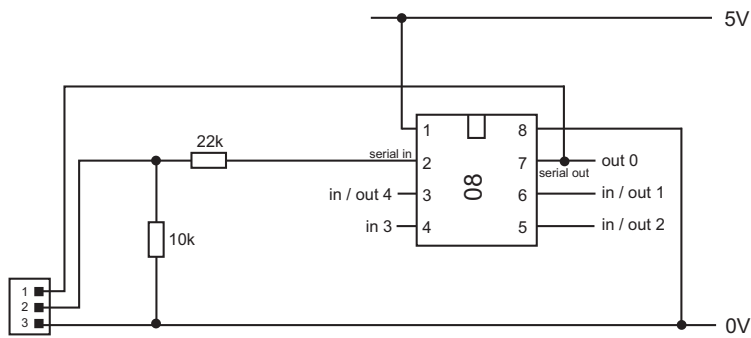

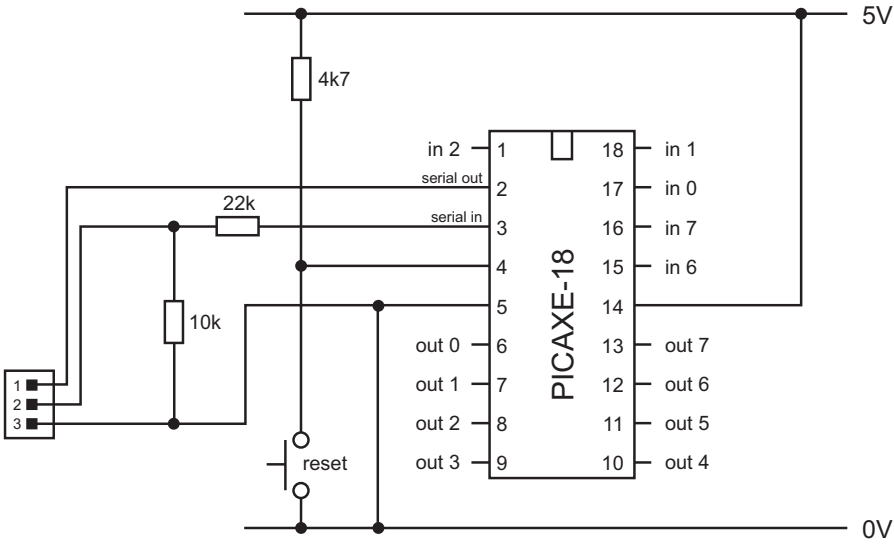

PICAXE Circuit Diagram (18 pin devices)

PICAXE Circuit Diagram (28 / 40 pin devices)

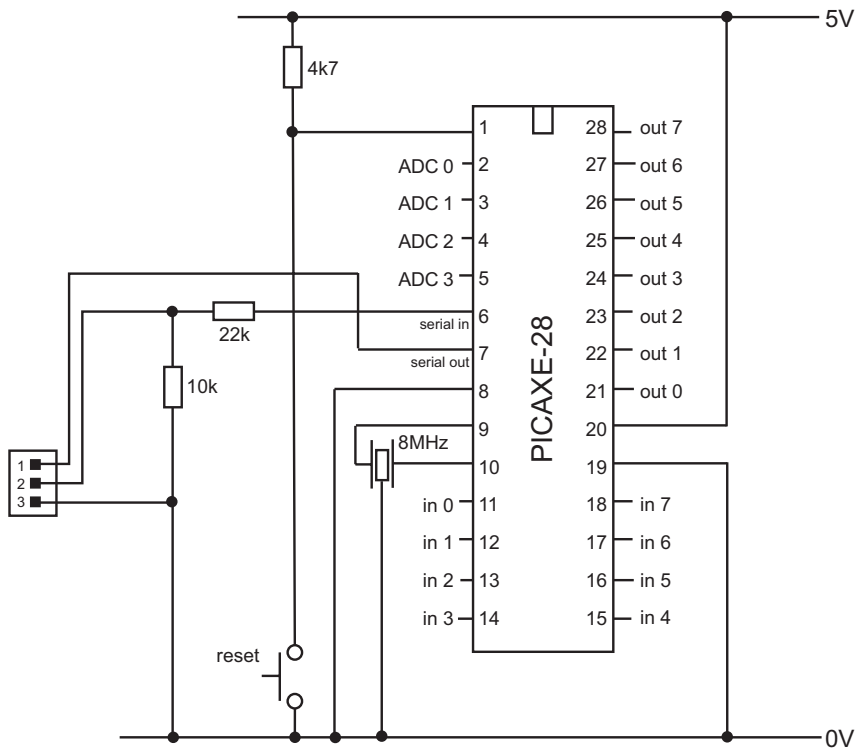

Using the PICAXE Development Board:

Important Notes:

1. Up to 3 PICAXE chips can be fitted at any one time in the following sockets:
 - Top socket - either 08 or 14 or 20
 - Centre socket - 18
 - Lower socket - either 28 or 40
2. Only one power source should be connected at any one time.
3. PICAXE chip polarity (pin 1 to top left) should be observed at all times.

Failure to observe any of these points may result in damage to the PICAXE chip.

PICAXE Input/Output Pin Connections:

Every pin of the PICAXE chip is brought out to a numbered position on a header beside the IC socket:

- top socket for 08 / 14 / 20 pin devices
- centre socket for 18 pin devices
- lower socket for 28 / 40 pin devices

Note that on the left hand side of the lower socket there are separate header points for the 40 pin (outer row) and 28 pin (inner row) parts. On all other parts the headers are common for all size parts.

The following connections are already made via the PCB:

08/14/20 pin socket

- power and serial download circuit

18 pin socket

- power and serial download circuit
- 4k7 pull up and reset switch on PICAXE reset pin

28/40 pin socket

- power and serial download circuit
- 4k7 pull up and reset switch on PICAXE reset pin
- 8MHz resonator

Computer Connection:

Only use the AXE027 PICAXE USB cable or AXE026 serial cable.

The standard PICAXE 22k/10k download circuit is used on each of the three download sockets, aswell as the fourth (inverted "N" RS232 communication) socket at the bottom of the board.

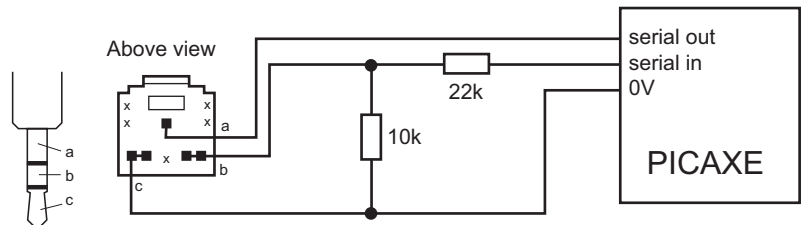

The 9 way D connector socket is used for True ("T") RS232 communication, not for new program downloads.

Reset Switch:

The reset switches only reset PICAXE chips with an external reset pin (18/28/40). To reset the 08/14/20 pin devices you must disconnect and reconnect the battery (or power supply).

Power Supply:

There are two options on how to provide power to the Development board, but ensure only one option is connected at any one time. The green PWR LED indicates power to the board.

1. Battery - connect a 4.5V (3xAA cell, not supplied) battery box to the screw terminals, ensuring correct polarity. Do not use 6 or 9V battery packs.
2. Power supply - connect a regulated 9V DC power supply with 2.1mm (positive

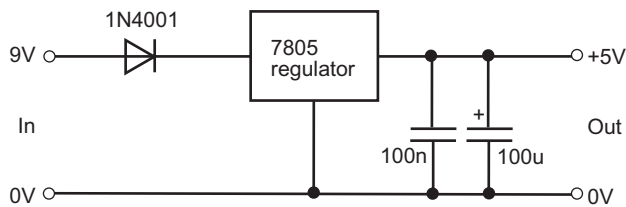

tip) connector (not supplied e.g. part PWR009A).

Do **not** use both power options at the same time!

The power supply connection is regulated to 5V by the 7805 regulator and reverse polarity protected by a diode. The screw terminal battery connection is not regulated and so connects **directly** to the PICAXE chip.

Do **not** use a 9V PP3 battery on this connection. Only use a 4.5V (not 6V) battery

pack.

Input and Output Header Summary:

Right hand header

V+	Positive power supply
0V	Ground
KD	Keyboard Data
KC	Keyboard Clock
IRR	Infra-red receiver
IRL	Infra-red LED
L3	Red LED L3
L2	Yellow LED L2
L1	Green LED L1
SVO	Servo header
LDR	LDR sensor
TMP	DS18B20 temperature sensor
SW3	Switch SW3
SW2	Switch SW2
SW1	Switch SW1
POT	Preset resistor
V+	Positive power supply
V+	Positive power supply
0V	Ground
0V	Ground

I2C header

WP	24LCxx EEPROM write protect (pulled low)
SDA	i2c Data (24LCxx and DS1307)
SCL	i2c Clock (24LCxx and DS1307)
OUT	DS1307 open collector output

RS232 header

N	TXD	Inverted polarity transmit (via 3.5mm jack socket)
	RXD	Inverted polarity receive (via 3.5mm jack socket)
T	TXD	True polarity transmit (via MAX202 / 9 pin socket)
	RXD	True polarity receive (via MAX202 / 9 pin socket)

SPI header

CS	25LCxx EEPROM Chip Select
SDO	25LCxx Data Out
SDI	25LCxx Data In
SCL	25LCxx Clock

Seven Segment Display

A-G	LED segments (no resistor provided)
DP	Decimal point LED (no resistor provided)
	Common cathode is connected to 0V

BAT Header

Optional 3V backup supply for DS1307 RTC
(note a SM socket may also be fitted under the board)

Input and Output Device Information:

Keyboard Connector (KD,KC)

The 6 pin mini DIN connector provides a connection and power to a computer style keyboard (not included). A 4k7 pull-up resistor is included on the data and clock lines.

Comamnds - kbin, keyin, keyed

Infra-red receiver (IRR)

The infra-red receiver circuit including pull up resistors is built onto the board. The infra-red signal may be generated via the on-board infra-red LED or an external device like a TV style remote control.

Comamnds - irin, infrain, infrain2

Infra-red LED (IRL)

The infra-red LED will light when a positive signal is applied. The cathode of the LED is connected by a 330R resistor to 0V.

Comamnds - irout, infraout

Output LEDs (L1, L2, L3)

Three LEDs are provided (L1 to 3). The LED will light when a positive signal is applied. The cathode of the LED is connected by a 330R resistor to 0V.

Comamnds - high, low, toggle

LDR Analogue Input (LDR)

The LDR is arranged with a 10k resistor in a potential divider arrangement. The LDR is connected between the input and V+, the resistor between the input and 0V.

Commands - readadc, readadc10

Preset Pot Analogue Input (POT)

The preset pot is a 10k device connected directly between the V+ and 0V power rails. The wiper of the preset pot is connected to the input.

Commands - readadc, readadc10

Digital Input Switches (SW1, SW2, SW3)

Three switches are provided. The input is tied low by a 10k resistor, with the switch connected between the input and V+. Therefore pressing the switch will result in a high signal.

Commands - if pin... then

DS18B20 Temperature Sensor (TMP)

The digital temperature sensor (located at the bottom right of the breadboard) and includes the 4k7 pull up resistor on the data line.

Commands - readtemp, readtemp12

Servo header (SVO)

The servo header provides a convenient way to connect a radio control style servo. The power supply is connected directly to the header (R & B) and the signal wire (Y) is connected to the SVO header.

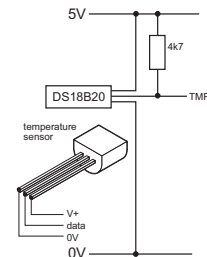
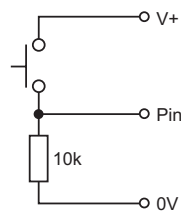
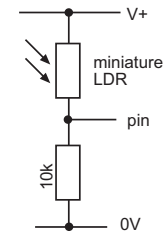
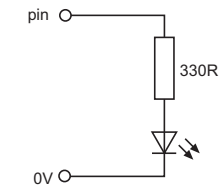
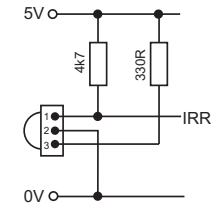
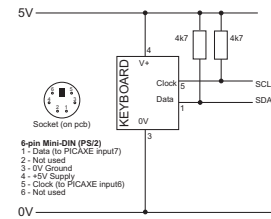

Commands - servo, servopos

SPI

The SPI header provides connection to the on-board SPI EEPROM socket, which may be fitted with a 25LCxx series EEPROM.

Commands - spiout, spiin, hspiout, hspiin

RS232

Two methods of RS232 communication are provided.

The inverted (N) method uses a 10k/22k style circuit to the 3.5mm jack socket. This allows the normal PICAXE download cable to be used for serial communication via the input/output pins.

The true (T) method uses a MAX202 circuit connected to the 9 way D serial socket. This requires a 9 way serial cable e.g. part CAB010.

Commands - serout, serin, hserout, hserin

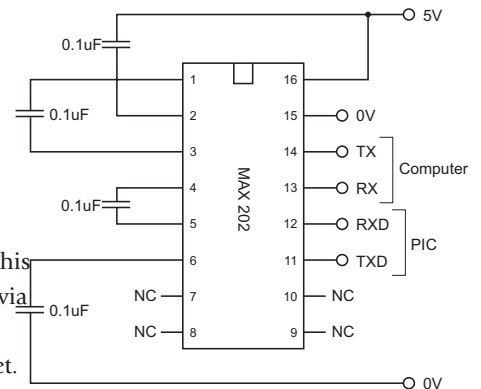

I2C

The I2C header provides connection to the on-board I2C EEPROM socket, which may be fitted with a 24LCxx series EEPROM, and to the DS1307 RTC socket. The SDA and SCL pins connect to both device sockets.

The WP pin connects to the EEPROM WP pin, and is pulled low by a 10k resistor.

The OUT pin connects to the DS1307 OUT pin. Note that this is an open collector (current sink only) type of connection.

A 3V lithium backup cell may be optionally connected to the DS1307 RTC chip. This can be achieved in either of two ways:

- by soldering a BAT004H-SM socket to the bottom of the board and inserting a CR2032 (BAT004) cell
- making a connection to the BAT header on the top of the board

Commands - hi2cout, hi2cin, readi2c, writei2c

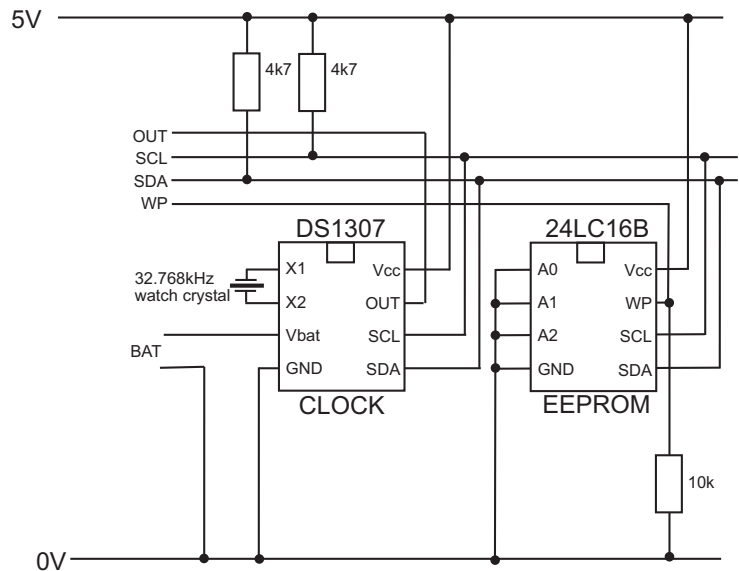

Prototyping board (breadboard):

The breadboard has 60 sets of vertical 5 hole connection sets (30 top sets and 30 bottom sets) for making connections. The vertical sets are not connected across the centre of the breadboard.

The breadboard also has 4 sets of horizontal 25 hole power rails (2 top sets and 2 bottom sets). The horizontal sets are connected all the way across the top (bottom) of the breadboard. The four rails are all independant (not connected).

Power connection points (marked V+ and 0V) are provided on the header beside the ends of the power rails for connecting power to the breadboard rails.